

white bream

Datasheet

E3 I I Mini-ITX Car power supply

PRELIMINARY INFORMATION! REGULARY CHECK WWW.WHITEBREAM.COM FOR UPDATES!

Version	Date	Author	Comment
0.2	Jan 12, 2004	Henk Blik	Preliminary version

White Bream	Terborchdreef 26	3262 NB	Oud-Beijerland	The Netherlands	www.whitebream.com
Description:	Product specification			E3 I I DS003 - Datasheet.sxw	
Project:	E3 I I		Internal use only		
Status:	Draft		Pages: 11		
 * E 3 1 1 D S 0 0 3 *					

1 Features

- Wide input voltage range
- Mini-ITX compatible
- Compact design
- Automatic startup and shutdown function
- Short circuit protected
- Customizable cable configuration
- Two years warranty ^{*)}

2 Description

The E311 car power supply is a high-efficiency DC/DC converter for Mini-ITX personal computer mainboards and other electronics that require 3.3V, 5V and 12V.

With over 50 watts of sustained power the E311 power supply exceeds the Mini-ITX power requirements to accommodate larger hard-drives. Peak power is 80 watts so that startup currents can be handled properly.

With car applications in mind, specific attention is paid to prevent battery drainage. This is achieved by a low standby current and with a microcontroller that safeguards the system's power state.

This microcontroller also deals with power sequencing: when power is applied to the switch input, it issues a pulse to the ATX power switch input to start the computer. Similar, when the switch input is deactivated, it issues again an ATX power button pulse to signal a power down event to the operating system.

One possible implementation of this power supply in a car navigation and entertainment computer system can be found on the website www.carpc.nl.

The E311 car power supply is available in a variety of deliverables including kit form for hobbyists and without output connectors for direct wire termination.

^{*)} See page 11 for additional warranty information
All specifications are subject to change, check the website for the latest information.

3 Applications

- Car MP3 computer systems
- Vehicle localization systems
- High performance navigation systems
- Maritime data acquisition computers
- Battery powered computers
- Wallbrick powered set-top boxes
- Entertainment system in campers
- Low-cost industrial control systems

4 Ordering information

E311V1STD	Standard power supply
E311V1KIT	Power supply in kit form
E311V1SMT	PSU kit with SMD placed

More ordering information, cables and accessories on page 8 of this datasheet.

5 Compatible hardware setups

- Epia 800 + 128MB + Western Digital WD800bb
- Epia M1000N + 256MB + Hitachi Deskstar D180GXP (120GB) + iMac slimline slot-in DVD ¹⁾
- 386SX + VGA + MIO + WD 1.2GB + FDD ¹⁾

¹⁾ To be verified.

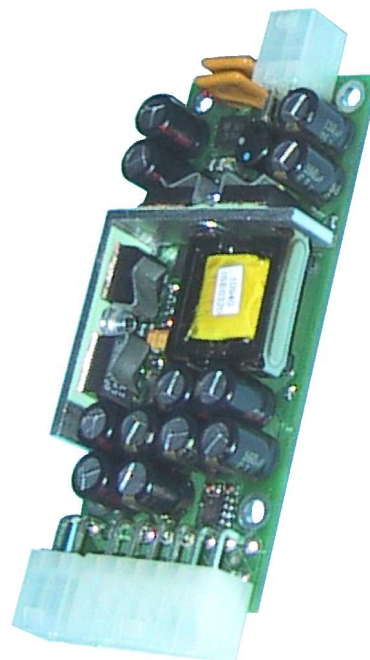

6 Maximum ratings

Parameter	Min	Max	Unit
Input voltage (V _{in} , operating)	-0.5	30	V
Input voltage (V _{in} , non-operating [PWR_ON = 5V])	-0.5	36	V
Input current		40	A
Switch voltage (V _{sw})	-0.5	30	V
PWR_ON voltage	-0.3	16	V
PWR_OK voltage	-0.3	8	V
Operating temperature range	-40	+85	°C
Storage temperature range	-55	+150	°C

Stresses beyond those listed here may cause permanent damage to the device. These are stress ratings only, and functional operation of the device at these or any conditions beyond the operating ratings is not implied. Exposure to these maximum ratings for extended periods may affect device reliability.

7 Operating ratings

Parameter	Min	Typical	Max	Unit
Output power		50	80	W
Efficiency ¹⁾	74	80	86	%
Input voltage (V _{in}) at 50% (typical) load ²⁾	8	13.5	22	V
Input voltage at 100% (full) load ²⁾	10	13.5	22	V
Input voltage on slewrate ³⁾		tbd		V/s
Battery protection threshold level	10	10.25	10.5	V
Battery protection trigger delay	45	60	75	s
Input current limit	6		12	A
Quiescent current (no output load)		12	20	mA
Standby current (no 5 VSB load)		8	12	mA
Poweroff current (initial & after watchdog intervention)		100	250	µA
Switch input on threshold (relative to V _{in})	65	75	85	%
Switch input off threshold	15	25	35	%
Switch input on slewrate		tbd		V/s
Switch input off slewrate		tbd		V/s
Switch input current		30		µA
Switch input current (with V _{in} = 0V)			11	mA
PWR_ON high voltage (pullup to 5VSB)		5		V
PWR_ON low input current		120		µA
PWR_ON high level input voltage	2.4			V
PWR_ON low level input voltage			1.2	V

Parameter	Min	Typical	Max	Unit
PWR_OK high voltage (pullup to 5V)		5		V
PWR_OK low voltage			0.4	V
PWR_OK sink current		~ 0	6.6	mA
Galvanic isolation		N/A		kV
Weight		65		gr
Recommended operating temperature range	0		50	°C
Acoustic noise level		tbd		dB
MTBF		tbd		h

Note 1: Under specified conditions; see figures.

Note 2: Operation below the battery low threshold level will initiate shutdown sequence.

Note 3: A slowly uncoming input voltage can cause the power supplies standby system to remain unpowered. Either increase poweron slewrate or apply a trigger on the Vsw control line.

8 Output ratings

Parameter	Min	Typical	Max	Unit
5VSB Output voltage	4.5	5.0	5.5	V
5VSB Ripple and noise ¹⁾	0	20	40	mV
5VSB Load current	0	1.5	2	A
3V3 Output voltage	3.0	3.3	3.6	V
3V3 Ripple and noise ¹⁾	0	15	30	mV
3V3 Load current ²⁾	0	1.5	2	A
3V3 Load current, forced air cooling ^{2, 3)}	0	3	5	A
5V Output voltage	4.5	5.0	5.5	V
5V Ripple and noise ¹⁾	0	25	50	mV
5V Load current ²⁾	0.5	5	9.5	A
3V3 and 5V shared load current ²⁾	0.5	5	9.5	A
12V Output voltage	10.8	12.0	13.2	V
12V Ripple and noise ¹⁾	0	25	50	mV
12V Load current ⁴⁾	0.1	1	2	A

Note 1: Ripple and noise figures are measured using a 100nF ceramic capacitor and a 10uF electrolytic capacitor, both in parallel with the load and a Hewlett Packard 54504A digitizing oscilloscope (measure Vpp, statistics enabled, maximum of Vpp after 5 seconds) according the recommendations of ATX Specification.

Note 2: The 3.3V rail is derived from the 5V rail by using a linear post regulator, capable of supplying up to 5 A. Current derived from this rail is thus not available on the 5V rail any more.

Note 3: Continuous full power of the 3V3 rail is only available when the power supply is cooled by forced air.

Note 4: Drawing the maximum current from the 12V rail causes ripple to exceed the maximum specified. This peak current is only intended for initial spinup of system drives.

9 Timings

Parameter	Min	Typical	Max	Unit
Startup delay before ATX pulse		250		ms
ATX pulse duration		500		ms
Standard delay before ATX powerdown pulse		15		s
Watchdog holdoff time after ATX powerdown		3		min

Note: All timing values have a tolerance of +/- 25%.

10 Figures



Typical performance curve with a evenly distributed load. 5VSB/0.75A, 3.3V/1.5A, 5V/2.5A, 12V/0.8A.

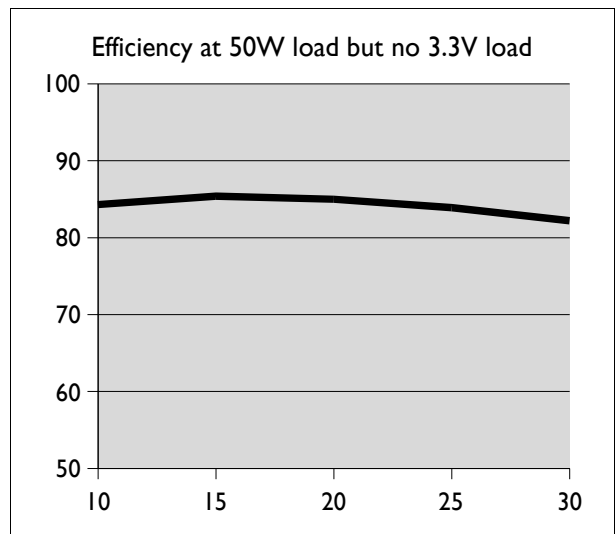

Typical performance curve with an evenly distributed load. 5VSB/1.5A, 3.3V/3A, 5V/4.8A, 12V/1.6A.

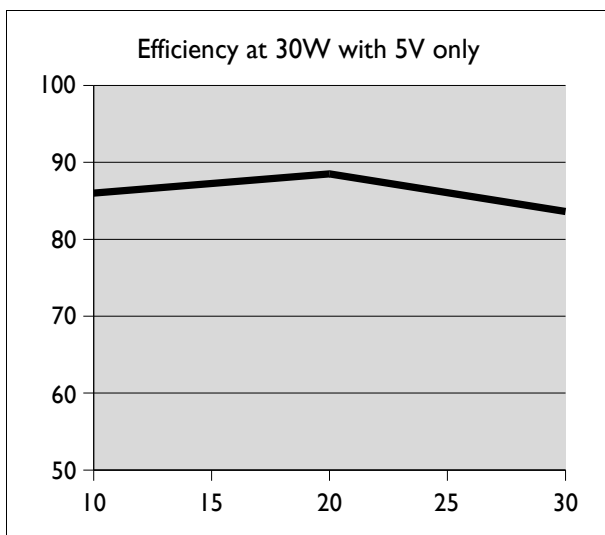

Typical performance curve with a limited load. 5VSB/1.5A, 5V/4.8A.

I1 Block diagram

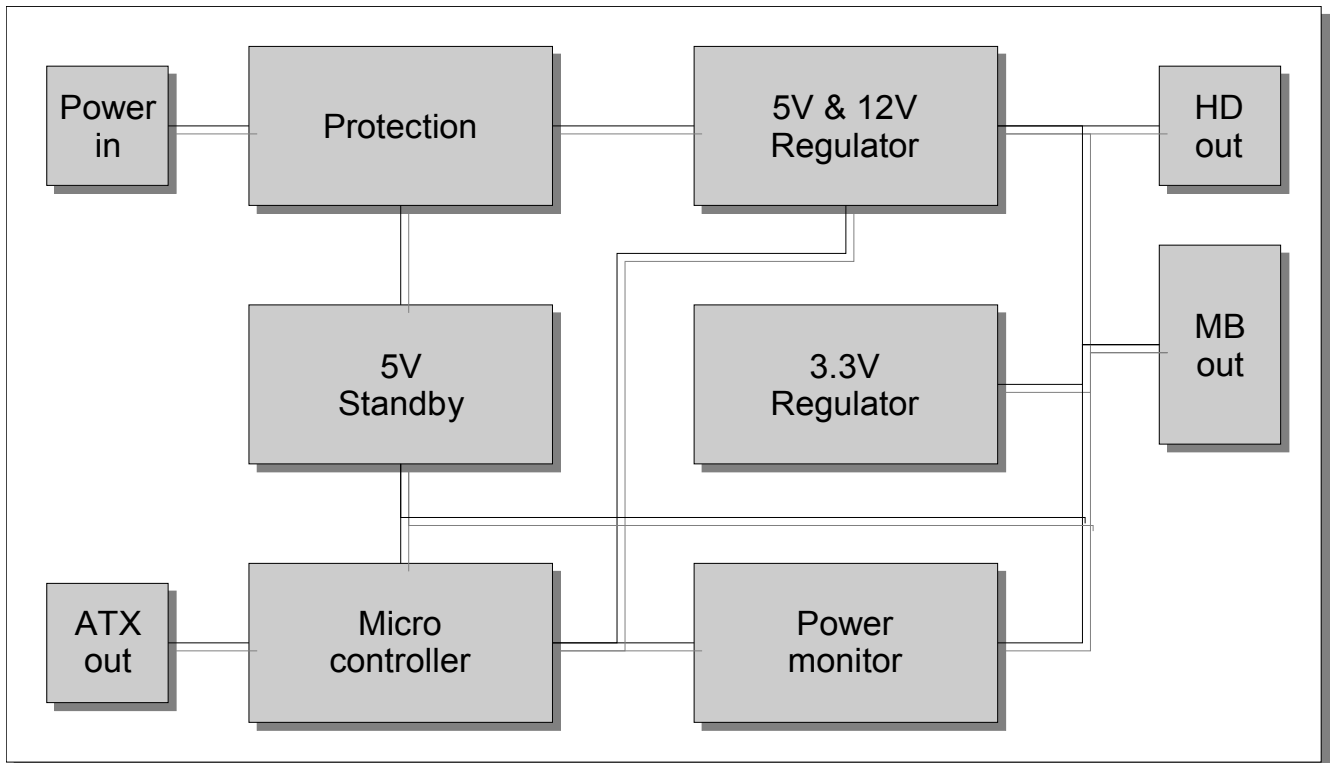

I2 Connection diagram

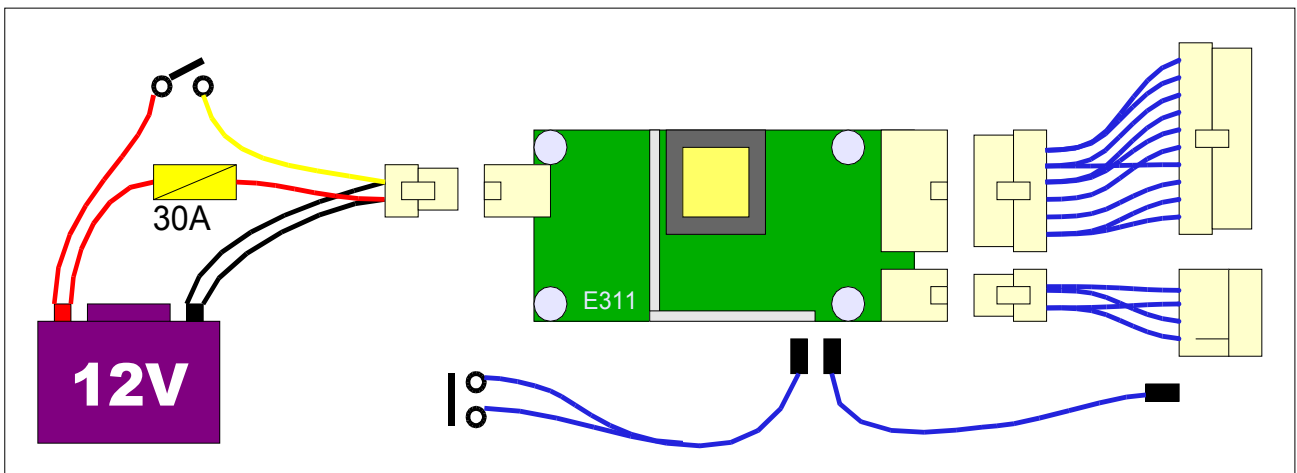

The fuse in the power lines is necessary when the main power source is capable of delivering more than 30A. Most applications using batteries therefore need this fuse. Also use this fuse when in doubt as it certainly won't do any harm. This additional fuse is needed because the electronic fuses inside the power supply are not capable of interrupting such heavy currents and may very well explode by trying to. In low-current applications, such as wall-brick powered systems the fuse is not needed.

13 Pinouts

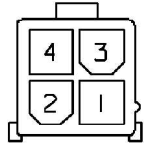
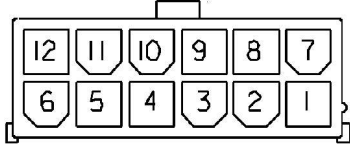
Molex MiniFit Jr.™ 3-, 4- and 12-pin:			
Matching P/N:	Molex 39-01-4030	Molex 39-01-2040 Amp 106527-4	Molex 39-01-2120 Amp 1-106527-2

Power input:

Pin	Name	Description
1	Vin	Input voltage [red]
2	Gnd	Ground (0V) [black]
3	Vsw	Switch voltage [white]

Mainboard output:

Pin	Name	Description
1	PWR_OK	Power good signal
2	PWR_ON	Power-on signal input
3	Gnd	Ground
4	5V	5 V
5	3V3	3.3 V
6	Gnd	Ground
7	Gnd	Ground
8	5VSB	5 V Standby
9	Gnd	Ground
10	5V	5 V
11	3V3	3.3 V
12	12V	12 V

Peripheral output:

Pin	Name	Description
1	GND	Ground
2	GND	Ground
3	12V	Motor power
4	5V	Logic power

Power switch output (2x):

Pin	Name	Description
1	OC	Open collector
2	GND	Ground

Pin 1 is marked with a small triangle on the printed circuit board. The headers are 1.25mm pitch 2-pin Molex jumper sockets (matching P/N 51021-0200).

The mounting holes of the power supply are connected to the ground plane. It is recommended to ensure solid contact with a metallic case.

14 Jumpers

JP1, next to the mounting hole.

Enable or disable the watchdog (see also the description of the powerdown behaviour).

State	Description
open	Disabled
closed	Enabled

The state of the jumper is tested during the ATX power down pulse.

JP2, next to the heatsink.

Select power down delay time (see also description of powerdown behaviour).

State	Description
open	Power down delay 15 minutes
closed	Power down delay 15 seconds

The state of this jumper is tested everytime the power supply is powered on by signalling the Vsw control wire.

15 Power sequencing system

A microcontroller takes care of power cycling. It has several functions: When power is applied to the supply input, it issues a pulse to the ATX power switch input to start the computer. Similar, when the accessory power line fails, it issues again an ATX power button pulse to request power down from the APM/ACPI aware operating system.

A watchdog then is started to safeguard the car battery from drainage. When this watchdog barks, power is switched off regardless what the computer thinks it's doing. For standby purposes the watchdog can be disabled. Also the shutdown period can be extended to 15, 30, 60, 90, 120, 180, 240, 360, 480 or 720 minutes by toggling the accessory power line.

When the input voltage drops below about 10.5V for one minute, then the system is powered down to protect the battery from drainage.. Normally this is done by initiating a normal powerdown sequence with an ATX pulse. When the battery voltage remains low during the standby period, the system is powered down completely (including the Standby power).

16 ESD Precaution

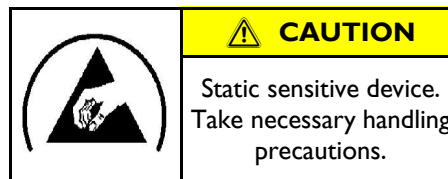

This assembly can be damaged by ESD. White Bream recommends that all devices be handled with appropriate precautions. Failure to observe proper handling and installation procedures can cause damage. ESD damage can range from subtle performance degradation and increased power consumption to complete device failure.

Please note that this applies only to the bare unit. The exposed power supply input is designed to meet automotive requirements with regard to transients and electrostatic discharges.

17 Compliance

The E311 Mini-ITX car power supply is designed to be compliant with the following norms; CISPR25, IEC61000-6-1, IEC6100-6-2, ISO7637-1, ISO7637-3, etc. following the recommendations of the EMC directive 89/336/EEC and parts of the automotive directive 85/54/EC.

Most of the on-board components have UL94V-0 rating. The nylon connectors have UL94V-2 rating.

The power supply is NOT YET verified to be compliant with these standards and directives.

18 Dimensions

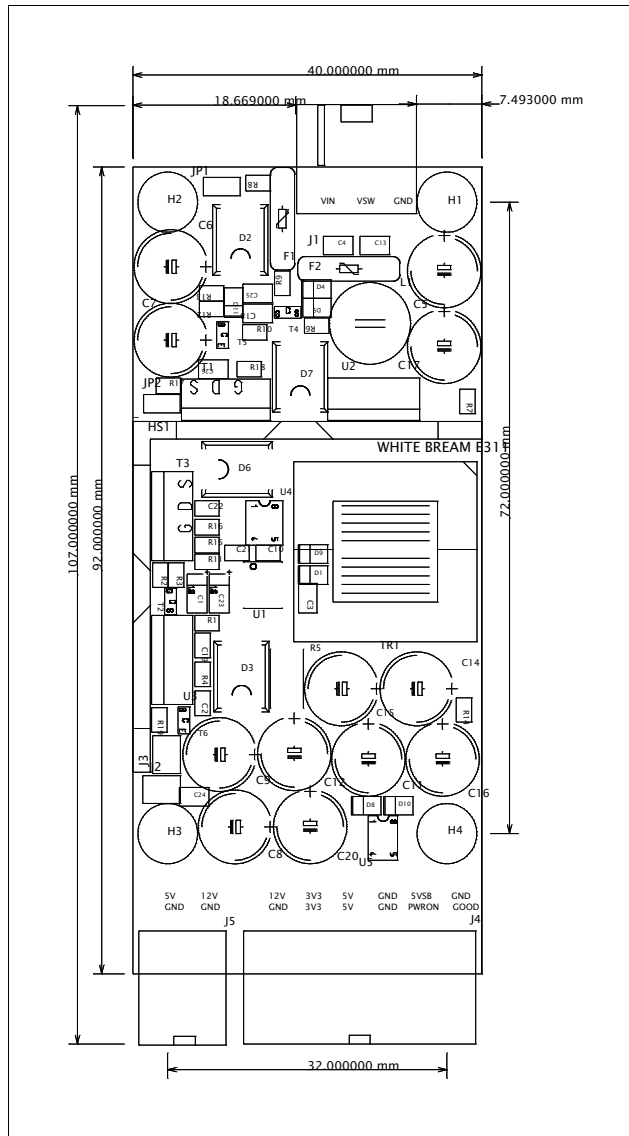

PCB Thickness: 1.6 mm
 Component height above board: 12.5 mm
 Extrusions below PCB: 2 mm

19 Ordering information

Products printed in bold typeface are standard products.

Power supply:

Productcode	Ordercode	Description
E311STD	69-311-101	Standard power supply. Includes standard cabling
E311OEM	69-311-102	Standard power supply without cables
E311CON	69-311-111	Standard power supply without output connectors mounted to facilitate direct soldering of wires (limited warranty)
E311ATX	69-311-112	Standard power supply with direct attached ATX output cables
E311KIT	69-311-121	Power supply in kit form (no warranty)
E311SMT	69-311-122	Idem but with surface mount components placed

Kits are supplied complete with printed circuit board, finished transformer, heatsink, connectors, surface mount components and conventional components, but without warranty.

Cables:

Productcode	Ordercode	Description
E311CB110	69-311-211	Input cable 2.5m
E311CB210	69-311-221	Mainboard cable with ATX connector
E311CB220	69-311-222	Mainboard cable with AT connector & power switch
E311CB310	69-311-231	Drive cable with one 5¼" connector
E311CB320	69-311-232	Drive cable with one 5¼" and one 3½" connector
E311CB330	69-311-233	Drive cable with two 5¼" connectors
E311CB340	69-311-234	Drive cable with two 5¼" and one 3½" connectors
E311CB410	69-311-241	ATX power button jumper cable with single header
E311CB420	69-311-242	ATX power button jumper cable with dual header

All cables except the input cable are 25 ± 1 cm.

20 Warranty

The two year warranty applies only to units manufactured and marked as such by White Bream. Power supplies assembled from kits by the end-user are not covered by this warranty. Warranty is void when maximum ratings are not obeyed or when the device is used in environments where these maximum ratings are likely to be exceeded. Malfunction caused by modifications on the unit void warranty, even when these modifications are approved. White Bream reserves the right to reject such units for repair or replacement. Properly applied modifications that do not interfere with proper operation and that are not the cause of a malfunction do not affect the warranty. Shipping of units is always at the expense of the owner.

21 Liability

White Bream and its suppliers shall not be liable for any direct, indirect, punitive, incidental, special or consequential damages that result from the use of, or inability to use, this power supply. This limitation applies whether the alleged liability is based on contract, tort, negligence, strict liability or any other basis, even if White Bream has been advised of the possibility of such damage. In jurisdictions that do not allow the exclusion or limitation of incidental or consequential damages, liability shall be limited to the extent permitted by law.

22 Disclaimer

White Bream products are not authorized for use in, or in connection with surgical implants, or as critical components in any medical, or aircraft, or other transportation devices or systems where failure to perform can reasonably be expected to cause significant injury to the user, without the express written approval of an executive officer of White Bream. Such use is at buyer's sole risk, and buyer is responsible for verification and validation of the suitability of products incorporated in any such devices or systems. Buyer agrees that White Bream is not liable, in whole or in part, for any claim or damage arising from such use and shall have no obligation to warranty such products. Buyer agrees to indemnify, defend and hold White Bream harmless from and against any and all claims, damages losses, costs, expenses and liabilities arising out of or in connection with buyer's use of White Bream products in such applications to the extent buyer has not obtained the express written approval of an executive officer of White Bream.

23 Contact

White Bream
Terborchdreef 26
3262NB Oud-Beijerland
The Netherlands

Company website: www.whitebream.com
Product webpage: www.whitebream.com/e311.shtml
Product literature: www.whitebream.com/script/download.pl?id=e311

General email contact: info@whitebream.nl
Sales contact: sales@whitebream.nl
Technical support: support@whitebream.nl